

ControlEdge™ PLC

Easy Integration and Flexible Deployment

Product Information Note

ControlEdge™ PLC dramatically reduces configuration, integration, and support costs while decreasing risk with embedded cyber security. Combined with Experion®, it minimizes downtime through unified support, and lowers total cost of ownership through extended system lifecycle.

Honeywell's PLC is part of the ControlEdge™ family, a next generation family of controllers providing unprecedented connectivity through all levels of process and business operations. The result is optimized operations and maintenance efficiencies that release personnel from manual processes. ControlEdge PLC is one of the first controllers supporting Honeywell's IIoT-ready initiative.



Figure 1. ControlEdge PLC

The ControlEdge Programmable Logic Controllers (PLCs), designed and developed by Honeywell is based on the proven platform of racks and power supplies. This advanced line of controllers, compliant with the IEC 61131-3 standard, offers impressive scalability for different environments and provides robust control in a wide range of applications.

ControlEdge PLCs can be deployed as part of Honeywell's unique LEAP™ project execution approach, enabling cloud-based execution for automation projects while eliminating complexity, saving time and lowering costs.

With the ControlEdge solution, industrial facilities are assured of utmost cost and performance benefits over the life of the asset. They will also realize significant value from simplified configuration and integration across their control architecture.

FEATURES & BENEFITS

- Tightly integrated with Experion, Honeywell's best-in-class Distributed Control System (DCS), Supervisory Control and Data Acquisition (SCADA) system, safety system and Honeywell's Field Device Manager (FDM) for smart field device management
- Modbus RTU, ASCII and user defined protocol on RS232 and RS485 for serial device integration
- I/O racks of various sizes and AC/ DC Power supply options
- OPC UA and EtherNet/IP protocols offer smooth integration to a broad range of devices and controllers
- Integration with third-party systems and devices such as motors, drives, and compressors
- Leveraging Honeywell's LEAP™ project methodology, it is the first PLC with HART enabled Universal I/O for greater configuration flexibility
- Optional redundant power supplies, controllers, and communication links
- Universal IO, Digital Input, Digital Output, Analog Input, Analog Output, Universal Analog Input, High Voltage Input modules
- Connects to Human-Machine Interface (HMI) through Modbus, EtherNet/IP, and OPC UA protocols
- Compatible with leading open network standards such as Modbus, EtherNet/IP, OPC UA and HART-IP
- Powerful IEC 61131-3 programming environment
- ISASecure EDSA Level 2 certified cyber security ensuring the safety of the system, personnel and critical information
- Supports on-process remote firmware updates
- Single vendor service and support across PLC, DCS, Safety System, Panel PC and Field Device Manager
- Subsea application support with MDIS protocol and a complete library of objects as defined in the MDIS Companion Specification
- ELMM as a migration solution from legacy IPC620
- DNP3 multi-master capability allowing simultaneous data collection from multiple SCADA

Designed to work with any SCADA system, ControlEdge PLC becomes a superior solution using Experion, leveraging common station hardware and HMI, LEAP project execution, faster field device commissioning, and improved device diagnostics. Embedded OPC UA, DNP3, Modbus and EtherNet/IP protocols provide smooth integration to a range of instruments and systems from multiple vendors. Built-in cyber security provides compliance to standards and safety of people, plant and information at the site. HART-enabled Universal I/O offers remote configuration and late design change flexibility for improved project implementation.

Superior Integration Capability

With Honeywell technology, industrial sites have a flexible way to efficiently access data in a seamless manner, ensuring easy configuration and maintenance. Honeywell can serve as a single vendor for all automation needs, including the DCS, PLC, SCADA, asset management with Field Device Manager, and an HMI panel.

ControlEdge PLCs are tightly integrated with the Experion control system architecture. By partnering with an automation vendor offering both DCS and PLC solutions, users have a single point of contact from project inception to support, substantially reducing CAPEX and OPEX.

Integration with Experion

Through use of open protocols, ControlEdge PLC is designed to work with any SCADA system. When combined with Experion, it becomes a superior solution. Enhanced ControlEdge PLC and Experion integration over OPC UA interface offers in-built PLC diagnostics in the Experion system, an integrated alarm summary, history, trend and reporting for both C300 controller and PLC - resulting in enhanced user experience with significant cost savings and ease of plant operations.

Auto-configuration of PLC data points provides a significant reduction in the integration effort, easy updates on the Experion Server, and faster project deployment. In addition, OPC UA named variable based mapping eliminates address mapping efforts and errors.

Native Peer to Peer communication between ControlEdge PLC and Experion C300 using CDA

eliminates protocol mapping errors and reduces integration time.

When you match an Experion Equipment template with a ControlEdge PLC, the cost of configuring the full solution is simplified even further. Experion and ControlEdge PLC have been designed to solve automation requirements in the oil and gas, mining, water and other process industries.

For more information, refer to the *Experion and Field Device Manager PINs*.

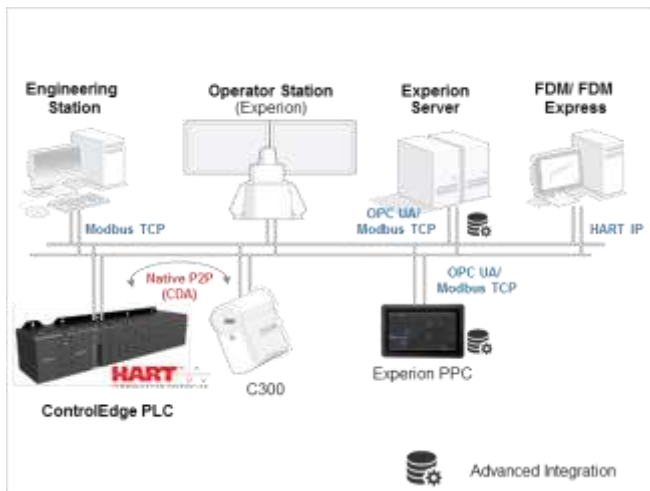

Figure 2. ControlEdge PLC, Experion and Experion PPC Integration

Experion HMIWeb Display Builder is the object-oriented tool for building and maintaining PLC HMI displays. It includes an object browser to easily navigate and make changes, a property window to enter and view parameters, and a structured list of shapes. Shapes can be dragged and dropped to quickly engineer new displays and modify existing ones.

The Experion HMI incorporates features developed from extensive consideration of human factors by the Abnormal Situation Management (ASM) consortium. Operators' situational awareness is optimized, fatigue minimized, and quick identification and response to abnormal situations promoted. These features are available both in standard system displays and user built displays where the HMIWeb Solution Pack library is used. For more information, refer to the Experion HMI PIN.

Integration with Experion Panel PC

The Experion Panel PC (PPC), provides a single HMI across PLC diagnostics and Experion system displays. The touch user interface allows you to operate from the equipment or from the control room easily without learning different systems. It also allows connection of the PLC to the Experion system with less effort, and improved integration with Experion over a secured (encrypted and authenticated) connection using node to node IPSec-based security for all protocols. Experion PPC also supports Automatic Point Configuration for PLC.

In all, the Experion PPC configured with Experion HS provides the following benefits:

- Better operator emergency response
- Seamless, quick start-up, and commissioning

- Transparent process view
- Easy, lean, and secure integration
- Lower training and maintenance overheads
- Improved total cost of ownership

Universal I/O HART and Field Device Manager Integration

ControlEdge PLC offers onboard HART support on any of 16 Universal I/O channels and HART-IP protocol support. Field Device Manager (FDM) provides fast and accurate commissioning of HART field devices. Rapid maintenance decisions are afforded through simplified diagnostics and fewer site trips. The combination of FDM and HART-IP protocol offers design flexibility using the HART-IP open standard and investment protection through the use of existing plant network infrastructure. Finally, FDM conveniently co-exists on the ControlEdge Builder workstation and is scalable to large sized projects.

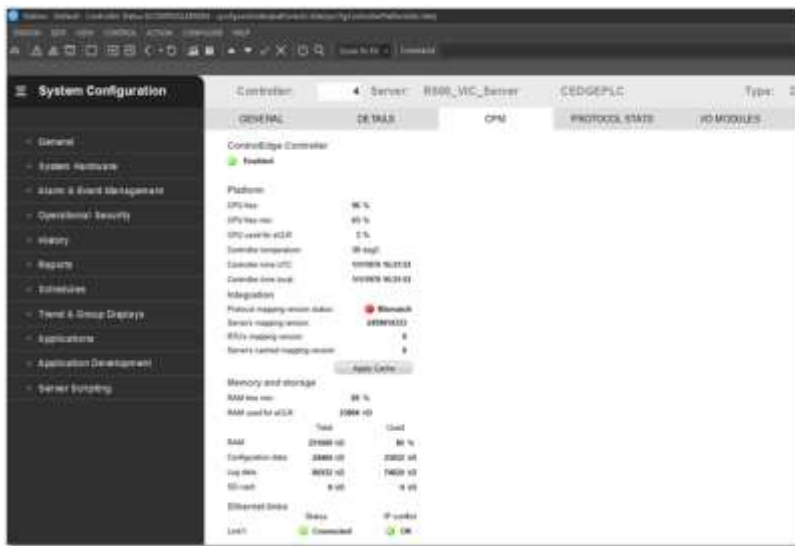

Figure 3. Simplified diagnostics

Universal I/O for Project Flexibility

Honeywell’s automation experience and innovative LEAP methodology are the key to increased flexibility – allowing industrial firms to optimize project execution. With LEAP, companies can realize significant capital savings on the total installed automation costs of a project, reduce rework costs, and minimize schedule delays.

Essential to the LEAP approach is the implementation of 16- channel Universal I/O modules (UIO) supporting HART signals, which offer flexibility in I/O type, eliminating the need for custom PLC hardware alignment with different I/O configurations and enabling simplified field device configuration and maintenance. Any field signal can be connected to any I/O channel. Deployment of UIO provides greater flexibility for late stage changes, such as configuration and design changes on a typical automation project.

The UIO module reduces equipment needs by reducing or eliminating marshalling, and because there is no need for hardware with different I/O configurations. The result is significant savings in spares inventory and associated costs.

The Value of HART

Distributed operations can require crews of field operators that travel each day over long distances and dangerous terrain. It is not only a large operating expense, but is also unsafe —and that is just the trip to site. ControlEdge PLC can help bring that requirement to an end. The traditional PLC strengths of logic control and good sub-system communications with local devices, alongside smart device integration with HART, is enabling better fault modeling at central locations. This means that each field operator is much more productive and can manage more remote sites than without the implementation of ControlEdge PLC. HART command support in ControlEdge PLC saves commissioning and installation cost as engineers can perform activities like calibration and loop integrity checks from engineering workstations. Multivariable field device support further reduces cost of wiring and installation equipment.

In figure 4, we show the ControlEdge PLC and FDM accessing both the HART device’s digitally accurate secondary variable and its diagnostic data. The operator can use Honeywell’s Field Device Manager to connect through to the HART device using HART IP.

For more information on smart device management, refer to the *Field Device Manager (FDM) PIN*.

I/O Module Choices

More I/O module options below provide flexibility in system design and reduce system cost:

- 32 Channel Digital Input (24VDC)
- 16 Channel Digital Input (120/240VAC)
- 16 Channel Isolated Digital Input (120/240 VAC-125VDC)
- 32 Channel Digital Output (24VDC)
- 8 Channel Digital Output (120/240VAC)
- 8 Channel Universal Analog Input (TC, RTD, other)
- 8 Channel Relay Digital Output (AC/DC)
- 4 Channel Pulse Input and Frequency Input
- 8 Channel Analog Output – (0-20 ma)
- 4 Channel Analog Output (0 to 20 ma)
- 16 Channel High level Analog Input
- 16 Channel Contact Type Digital Input

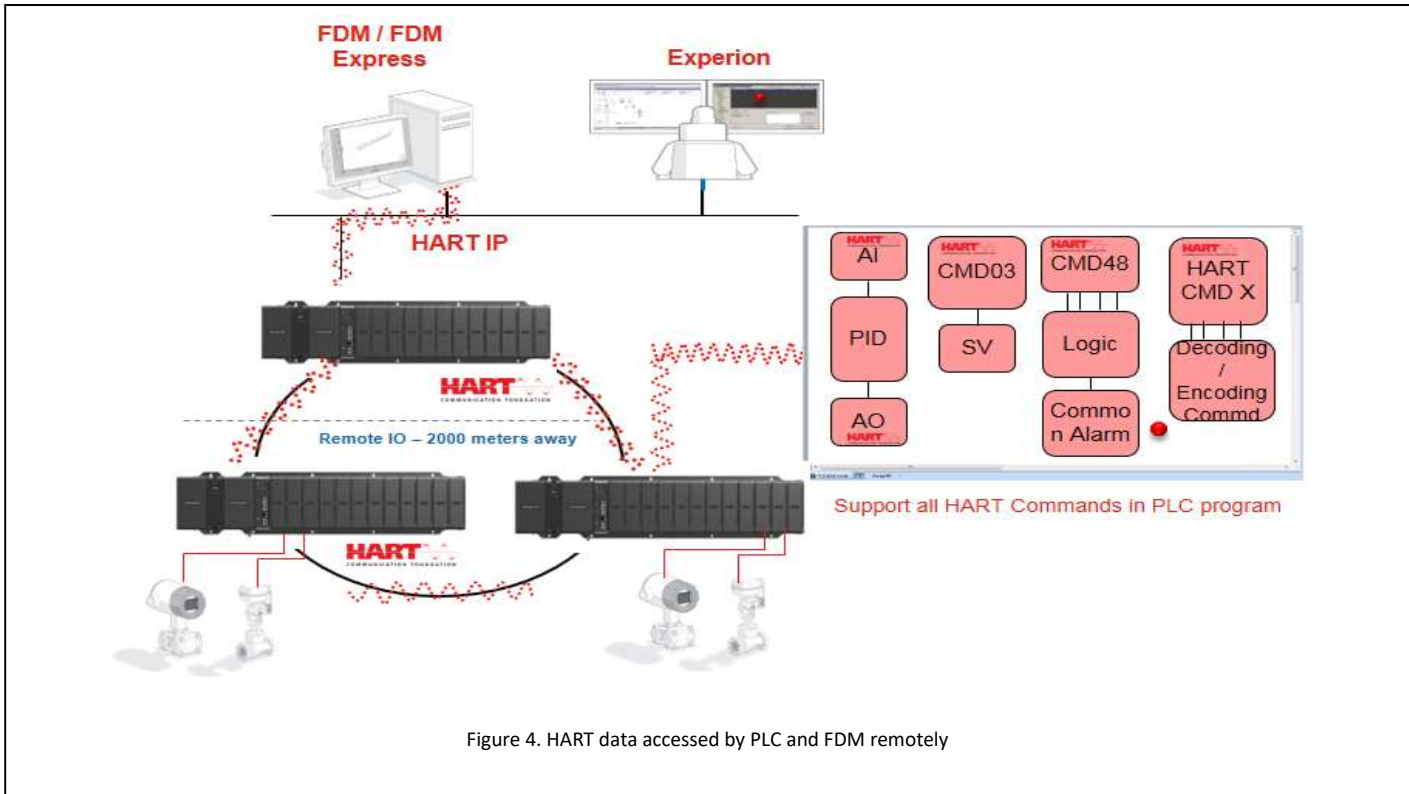

Figure 4. HART data accessed by PLC and FDM remotely

Remote Terminal Panels

Optional DIN rail mounted Remote Terminal Panels (RTPs) are available for use with pre-wired cables to reduce installation time and labor expense. Three cable lengths are available: 1.0m, 2.5m and 5m. RTPs switch field power to allow module removal and installation under controller power.

Serial Communication Module

Scalable serial communication allows integration of a wide range of systems over Modbus RTU, Modbus, ASCII and User Defined Protocol. The cost of the solution is reduced with two RS232 and two isolated RS485 ports on the same hardware module.

Controller Redundancy

Honeywell’s redundancy is ready to go. There is no need to program any differently from a non-redundant controller. ControlEdge PLC takes away the complexity. No additional infrastructure is required to synchronize the data between CPMs.

Enhanced Hardware Design

A security cover prevents unauthorized access to the physical mode switch and SD card, and reduces the risk of network cables being accidentally unplugged. It is also transparent for viewing the diagnostic information from LEDs on the CPM. A wide-access I/O door opens

out, providing clear access and visibility to the labels and terminal blocks for easy wiring.

Additional safety and Hazloc certifications include: CE, UL US, UL Canada, RCM, CUTR, FM Class 1 Div 2, CSA Class 1 Div 2, ATEX Class 1 Div 2.



Figure 5. Redundant Controller and Power Supply

Robust Cyber Security

Honeywell’s embedded cyber security supports compliance, reduced risk, and availability. Ours is the first PLC that is ISAsecure Level 2 certified. Features include secure boot to prevent uploading of unauthorized software, and a built-in firewall to reduce exposure to denial-of-service attacks and message flooding.

In addition, PLC communication is secured using IPSec. This prevents man-in-the-middle attacks and protects ControlEdge PLC from unauthorized access. Encryption for critical data employs NSA Suite B recommended algorithms. This supports easy configuration and provides certificate-based authentication.



Figure 6. PLC Communication Secured with IPSec

At the forefront of industrial safety and security, Honeywell offers Industrial Cyber Security Solutions and Managed Services that help protect the availability, safety and reliability of industrial control systems and site operations. Honeywell improves business performance by reducing the risk of incidents, faults and failures that disrupt normal operations. This means customers can have greater confidence in the security of their PLC installation.

Embedded EtherNet/IP Protocol

EtherNet/IP Server and Client capabilities embedded on PLC controllers provides engineering flexibility to choose from different topologies such as Star Ring, Linear or Mixed. Connectivity to a range of I/O devices like drives, I/O modules, valves, sensors, HMI panel and controllers supporting EtherNet/IP improves access to process and diagnostics information crucial for control strategies. Multi-vendor device connectivity allows you to choose from several EtherNet/IP certified vendors and provides freedom to select the right devices for application needs. EtherNet/IP provides investment protection for the customer working on migration and brownfield projects by allowing easy connectivity to existing controllers, I/O devices and HMI infrastructure.

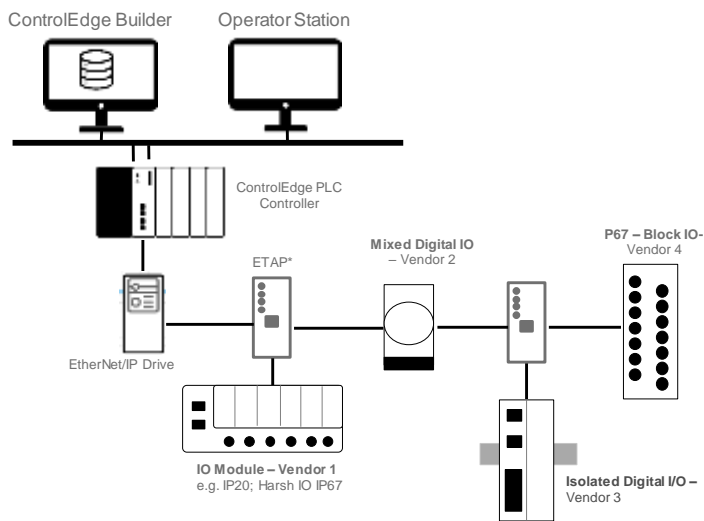

Figure 7 – Multivendor EtherNet/IP device and I/O module connectivity

Embedded OPC UA Protocol

As the protocol of choice for IIoT, OPC Unified Architecture (UA) provides secure, reliable and vendor-neutral transport of raw data and pre-processed information from the sensor and field level up to the manufacturing level. Using this open protocol – embedded directly in the controller itself as a client and a server – the Honeywell ControlEdge PLC provides users with the flexibility to choose between interfaces while simplifying integration with a wide range of third-party systems and devices. Interoperable multi-level and multiplatform open communication provides flexible and scalable design, enabling standardization with less hardware.

DNP3 Protocol

DNP3 is a preferred choice of communication for the devices which are located in geographically remote areas like pipelines, where there is a risk of communication losses with the remote devices. ControlEdge PLC provides full support of DNP3 protocol. With the event buffer feature, DNP3 protocol stores data in a flash or SD card when the communication with SCADA is lost, and the events are received in the SCADA server when the communication is restored. The ControlEdge PLC DNP3 multi-master capability allows simultaneous data collection from multiple SCADA masters. Coupled with Experiion history backfill and rich HMI features, the solution delivers unique value.

ELMM (Enhanced Logic Manager Module)

Enhanced Logic Manager Module with ControlEdge PLC helps users who want to modernize and migrate Logic Managers on their TDC 3000, TPS or Experiion TPS systems with an IEC 61131-3 based controller. The existing IPC/LCS 620 controller and I/O modules are replaced with the ControlEdge PLC and ControlEdge 900 I/O modules, improving control performance while offering greater flexibility and lower costs. Migrating from the obsolete LM platform to an Experiion hardware platform with the

latest ControlEdge PLC ensures better lifecycle support.

Additional benefits include:

- Replace obsolete IPC620 processor along with its I/O module by the latest ControlEdge PLC and its I/O module.
- Replace the LMM by the ControlEdge PLC and enable connectivity to EUCN network by adding EUCN protocol support on the PLC.
- Convert all the ladder logics in the IPC620 processor to its equivalent ladder logics/function blocks on the ControlEdge PLC.
- Retain the user's intellectual property and user experience intact, by allowing a restore of existing checkpoint, thereby enabling the usage of all existing graphics, trends, and control groups.

MDIS (MCS DCS Interface Standardization)

Protocol

ControlEdge PLC supports a library of custom function blocks for MDIS communication. The ControlEdge PLC can act as a responder to the Topsides C300 controllers using the Honeywell Control and Data Access (CDA) protocol. Thus, the PLC can be a peer to the C300 allowing direct transfer of process control signals required in the Topsides controllers.

The MDIS library has a set of OPC UA function blocks representing all the MDIS OPC UA object types as defined in the MDIS OPC UA Companion Specification V1.2. The MDIS OPC UA Object function blocks are used to obtain data from MDIS OPC UA compliant Servers.

For each MDIS object type, the specification identifies a set of data variables as well as method definitions. The MDIS function block library incorporates the data variables into each block as function block parameters or 'pins'. Separate method function blocks are provided for each of the methods defined in the specification.

Benefits:

- The combined ControlEdge PLC and Experion Server UA Client architecture provides a tightly integrated Experion solution for Subsea application

- Greatly reduces engineering cost associated with integration
- Additional Subsea housekeeping and diagnostic data can be accessed directly from the Experion server OPC UA client

ControlEdge Builder — An Integrated Configuration Environment

ControlEdge Builder is ControlEdge PLC's integrated configuration tool to design, configure, program and maintain your PLC investment. ControlEdge Builder is fully compliant to IEC 61131-3, supporting all five programming languages.

- Ladder Diagram (LD)
- Function Block Diagram (FBD)
- Structured Text (ST)
- Instruction List (IL)
- Sequential Function Chart (SFC)

In addition to the basic function blocks that come with an IEC 61131-3 environment, ControlEdge Builder includes Honeywell designed function blocks derived from our extensive industry experience and family of market leading automation controllers. Function blocks include PID, Device Control, Auto Manual, Fan Out, and Ratio Control. A HART command function block improves plant operation and device diagnostics, ControlEdge Builder is designed to work locally or remotely to the controller using TCP/IP. Personnel can program on site or from a remote central location to save time and mitigate the need for site work. In addition, a common builder between ControlEdge PLC and ControlEdge RTU reduces training and maintenance cost.

Remote Firmware Upgrades

Being able to remotely upgrade controller firmware is very important when there are several controllers geographically distributed. ControlEdge Builder's firmware update procedure is specially designed to account for low bandwidth, unreliable networks and ensure uptime of the controller and reliability.

Remote Diagnostics

Just as important as being able to remotely program and upgrade ControlEdge PLC is being able to remotely diagnose the health of the PLC. ControlEdge Builder provides a high definition analysis of the health scenario, leading to fewer site visits.

Scalable to a Broad Range of Applications

Honeywell's PLC solution enables you to configure a control system with functionality to suit your specific needs. The controllers are scalable not only in their speed of processing, but also in their performance characteristics. In addition, they offer networking options across different communication standards.

ControlEdge PLC is designed to optimize small unit applications ranging from motor control and HVAC systems, to pumps, generators, and more. It is also ideal for process industry applications such as waste water treatment, instrument air handling, coal and ash handling, chiller controls, and drying equipment.

LEAP for ControlEdge PLC

Application simulation capabilities for engineering teams enables development and testing applications without the need for PLC hardware. Our Virtual Engineering Platform support enables project execution and testing in the cloud from multiple locations. LEAP support reduces project risk and cost by allowing late binding of hardware and software.

Expert Service and Support

Honeywell has been recognized as an automation industry leader for more than four decades. Our

technology is installed in some of the largest refineries, plants, mills and mines in the world. Honeywell automation systems are easy to install and use, and are the most reliable and scalable systems available. 'Total Care' and SESP service offering is available for ControlEdge PLC. Refer Total Care Field Services for Modular Control Systems' brochure for more details.

An application migration tool, ControlEdge Transition R101, is now available for Allen-Bradley legacy PLC migration to ControlEdge PLC. It includes extensive pre- and post-migration reports; the result is an improved project schedule.

Honeywell understands that knowledgeable support and implementation services—delivered when and where they're needed—are critical to the success of any automation project.

For More Information

Learn more about ControlEdge PLC – Easy Integration and Flexible Deployment at our website www.honeywellprocess.com/PLC or contact your Honeywell account manager.

Honeywell Process Solutions

1250 West Sam Houston Parkway South
Houston, TX 77042

Honeywell House, Skimped Hill Lane Bracknell,
Berkshire, England RG12 1EB UK

Building #1, 555 Huanke Road, Zhangjiang Hi-Tech
Industrial Park, Pudong New Area, Shanghai 201203

www.honeywellprocess.com

PN-16-06-ENG

July 2019

© 2019 Honeywell International Inc.

Experion® is a registered trademark, and ControlEdge™, DSA™ and LEAP™ are trademarks of Honeywell International Inc.

Honeywell