

DRIVING PROFITABILITY IN SPECIALTY CHEMICAL MANUFACTURING WITH PERFECT-FIT CONTROL SOLUTION

PlantCruise by Experion® - Your control solution partner for greater process efficiency, batch repeatability, production flexibility, and agility



Introduction

Specialty chemical producers supply products that enhance the performance of consumer and industrial goods from pharmaceuticals to paints and adhesives. There are thousands of different specialty chemicals produced and supplied to a wide range of industries. SRI Consulting describes specialty chemicals as: “chemical products that are sold on the basis of their performance, rather than for their composition. They can be single-chemical entities or combinations of several chemicals whose composition sharply influences the performance of the product.¹”

In order to compete, specialty chemical companies offer a broad range of high-quality products, but what they all have in common is the need to be competitive which requires:

- Rapid product introduction to market to capitalize on R&D investment
- Greater production flexibility to capitalize on opportunities for new products
- Control manufacturing cost for high profitability
- Consistent and reliable operations to deliver product on time, every time

Table of Content

Introduction	2
PlantCruise by Experion®- Purpose-built solution for Chemical	4
Control System Platform- PlantCruise	5
Key Features	7
Batch Automation	9
Complementary Offerings	10
Summary	13

Unique challenges need specialized solutions

Leveraging our experience in continuous and batch automation, Honeywell has provided solutions for applications as diverse as agricultural chemicals, paints and pigments, synthetic fibers, polymers and resins, polysilicon and pharmaceutical ingredients.



With material costs, labor, utilities, and overhead accounting for over 50% of manufacturing costs, it is key for plant operations to perform at peak efficiency to improve yield.

The right automation solution can meet this goal by addressing needs for product reliability, quality, agility, and efficiency – the keys to a sustainable competitive advantage. Product reliability requires tight integration between manufacturing and sales to know what to make in real time. Then, you have to be able to rely on production assets to deliver the product per the schedule. Product quality requires consistency and controlled results in every aspect of production operation – from people to equipment, and the process itself. Agility requires the flexibility to adapt and respond to market opportunities while still making existing products profitably.

PlantCruise by Experion®- Purpose-built solution for Chemical

Honeywell's solution for specialty chemical sites addresses all these requirements in one scalable, integrated offering within the PlantCruise by Experion environment. Based on proven Experion Process Knowledge System (PKS) system, PlantCruise offers various system functions and applications that are aimed at delivering safety, compliance, reliability, and efficiency and are inherently available in the context of batch production. In addition, data from these various functions is presented in an integrated operating environment.

Honeywell is a leading automation solution provider in the chemicals market, present in every region of the world.

Honeywell provides scalable systems and solutions to a variety of chemical plants from small single product plants to world-scale petrochemical complexes. Eight of the top 10 specialty chemical companies use Honeywell systems and solutions. Leveraging our experience in continuous and batch automation, Honeywell has provided solutions for applications as diverse as agricultural chemicals, paints and pigments, synthetic fibers, polymers and resins, polysilicon and pharmaceutical ingredients. This experience and know-how were leveraged to create a solution specifically for specialty chemical sites, which provides the following:

- Scalability and flexibility from systems to applications to address the wide range of processes in these markets

- Operational environment enabling maximum efficiency for sites with limited resources through integrated operator workflow, real-time monitoring and mobile worker tools
- A reduction of manufacturing costs via tools and capabilities like batch automation, advanced process control and material handling
- Features that minimize total cost of ownership such as a global database, integrated tag configuration and built-in functionality
- Manufacturing agility through capabilities like online updates, automated equipment procedures, wireless offerings and simple drag-and-drop configuration for new production strategies
- Features that help optimize production cycle time and improve reliability such as providing controller-based batch recipe execution and alarm management

In addition to the platform, customers expect system support throughout the expected life cycle. PlantCruise customers are backed by Honeywell's Technical Assistance Center (TAC) for system support.

Trained, experienced TAC engineers provide telephone troubleshooting support, prompt answers to questions regarding procedures, documentation, operation, service, training and system enhancements. Support from TAC may include reviewing operational procedures, analyzing software and memory dumps, and recommending what diagnostics to use.

Control System Platform- PlantCruise by Experion

With PlantCruise, your specialty chemicals manufacturing operation will have greater agility to respond to new customer demands and changing product requirements. It is a powerful, yet practical solution offering advanced optimization and batch control technology usually found in larger DCS platforms – but at a more affordable price.

PlantCruise allows multiple batch recipes to execute completely in a reliable controller environment. This type of batch system offers a higher level of performance than a typical server-based system. The absence of a separate batch server removes associated costs and security/maintenance issues, and eliminates communication latency.

Common engineering and operating tools for batch also provide a single, consistent platform for batch development and execution in compliance with S88 industry standards.

PlantCruise is optimized for mid-scale projects requiring a combination of loop, logic and batch automation. Any size installation benefits from access

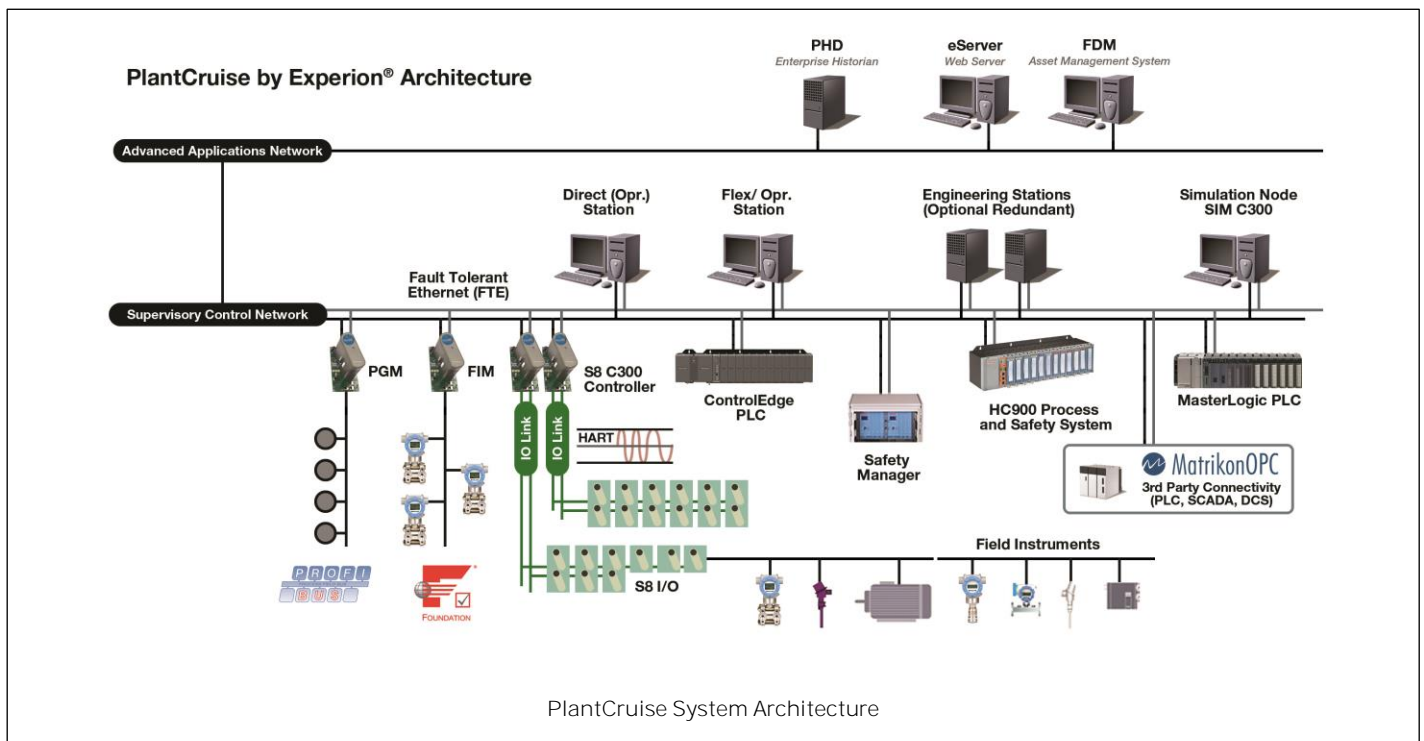

to a robust historian, controller-based batch sequencing, advanced control, and reporting capabilities.

The solution can scale from one engineering station, one operator station and one controller to multiple operator stations, redundancy and batch management. Also, the system provides reliable communication with third-party devices and drives, like PLCs, weigh scales and motor drives, integration of SCADA data and multiple I/O bus options. Because PlantCruise is based on the Experion PKS platform, there are several major benefits that mid-scale sites can realize.

Faster Projects and Reduced Lifecycle Costs

PlantCruise provides an agile automation platform to help manufacturers stay competitive, meet customer demands and respond quickly to opportunities. PlantCruise includes a number of pre-built features like composite tag structures, over 300 standard displays and condition handlers. For example, once a point is built and loaded to the controller, a detail display for the point is automatically available on any operator station. Additionally, PlantCruise provides integrated tag configuration so that a point and its associated alarms, history, and management of change are all configured at the same time in the same view.

With only one database for the entire system that can be accessed by all system functions, the need for building and maintaining multiple databases is eliminated. The configuration of interlock logic, control strategies, sequences and similar functions are done via drag-and-drop operations from prebuilt lists. Bulk build tools, template duplication, and other productivity tools are also included in this unified engineering environment. These capabilities translate into faster projects and less engineering effort to make ongoing changes to your automation strategy over the life of your system. Experion users have reported savings of \$10-20k per year on support alone.

Increased Uptime

Delivering quality products and meeting customer commitments are critical to business success. With PlantCruise, you can easily make changes to your automation configuration without stopping production. PlantCruise supports incremental editing and loading of control strategies online, addition of I/O, controllers and control strategies, and online upgrades. This allows customers to adapt to new challenges while still delivering on current promises. PlantCruise also includes a simulation functionality to test changes before putting them on process – without any special software or test programs.

PlantCruise leverages Experion architecture to provide data integrity and determinism so that you know when your logic will be processed. PlantCruise is available with redundant controllers and servers to provide heartbeat failover operations. Tools needed to manage and monitor the system are integrated into PlantCruise. For example, system resources like memory, processor utilization and disk drive space on the Experion nodes

are monitored and can generate alarms on the operator window if they reach critical levels.

Diagnostics from PlantCruise controllers are also available at the operator stations. Finally, PlantCruise ships with all the necessary software to provide an interface to the operator. Honeywell ensures that the system components work together and that new versions of system software are compatible with other system components. These built-in features mean that PlantCruise system is ready to deliver right out of the box.

Improved Operational Efficiency

Honeywell's control platforms are built to optimize the operator experience. To increase operator effectiveness, Honeywell leads the Abnormal Situation Management (ASM) Consortium, a group of companies that have spent over 10 years and \$40M researching abnormal situations caused by equipment failure, human error and security breaches that can lead to extreme financial loss and excessive damage caused by disrupted production, fires, explosions and toxic emissions. ASM Consortium research has improved integration of alarm, event, and alert management tools and provided guidelines to increase operator awareness, decision-making abilities and responsiveness, reducing operator-related incidents by as much as 40 percent.

PlantCruise has a sophisticated and rich alarm and alerting system, capable of handling alarms and alerts for your process. Experion is the first system to incorporate a "from the ground up" open alarm and event system. This alarm system supports not only Experion application alarms, events and messages, but also provides full integration with third-party alarms and events via OPC. Comprehensive commenting and annotation capabilities are provided to capture "knowledge" about alarms and events as it happens.

Designed to conform to the ASM Consortium's recommended guidelines, the standard alarm summary display allows operators to focus on the problem.

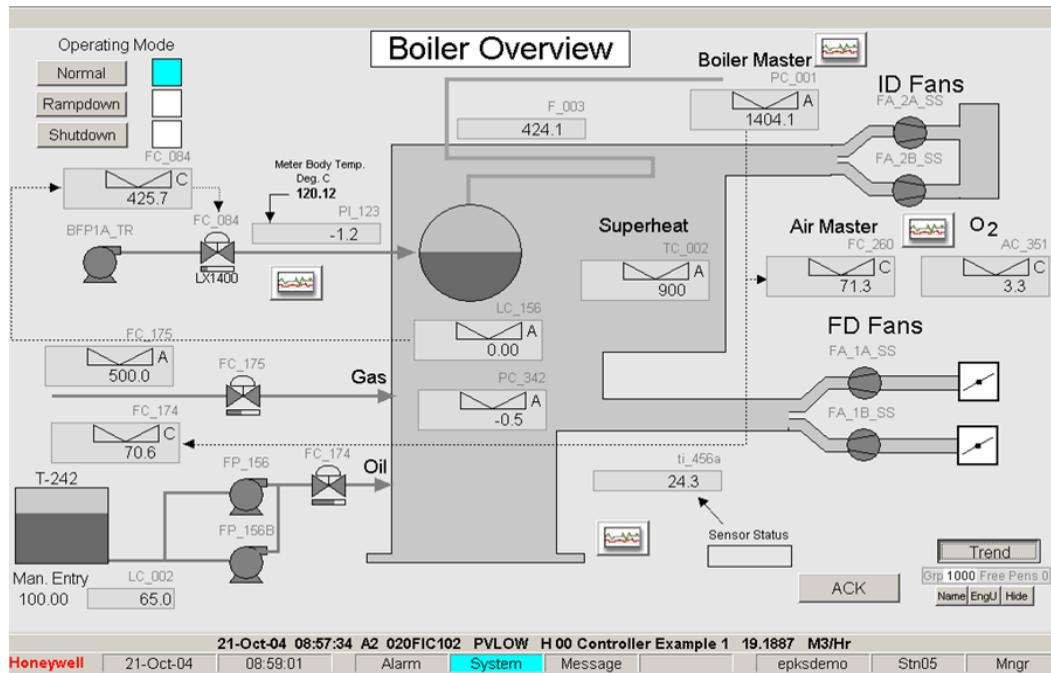

ASM Compliant Graphics for PlantCruise

- Location pane supports rapid alarm filtering and provides summary alarm count details.
- Detail pane shows extensive alarm condition details.
- Location pane shows alarm counts for a particular asset.
- Alarm summary columns can be customized to suit individual site or operator requirements. Fields can include the actual trip value and current live value among many other fields.
- View Configuration creates, saves and recalls custom operator alarm views.
- Alarms can be filtered by priority.
- Repeat alarm handling summarizes repeated alarms by including details on the time the alarm originally occurred, the time it last occurred and the total number of times the alarm occurred.
- Operators can easily add comments to alarms and events from the alarm summary display either individually or per page. On custom graphics, alarms can similarly be acknowledged on an individual or per page basis.
- The event summary lists events that occur in the system such as alarms, alarm acknowledgments, return to normal, operator control actions, operator login and security level changes, online database modifications, communications alarms, system restart messages and more.
- Experion allows the engineer to configure custom alarm priority colors.
- Users can configure archive functionality to store events online as well as to network servers or removable media to access at a later date.
- System status display provides the operator one place to review the health and status of all Experion components.

During execution, operators can monitor and view the details of interlock logic, control logic, sequences and other functions that are executing in the controller. This on-line view shows operators which elements of the function are okay and where there might be problems. The graphical interface will show the blocks while executing with live updated values and color codes for discrete signals. The view is accessible on operator graphics via double-click action by the operator. The views are created automatically by PlantCruise when a function is built in the controller. This function is helpful for verifying a control sequence or for troubleshooting a process problem. One small site was able to reduce operator calls to equipment and instrumentation staff by 90 percent during production, due to this built-in capability of Experion.

Key Features

PlantCruise enables chemical companies to realize the performance advantages of a true distributed control solution at a reduced cost. This purpose-built DCS can be tailored to fit your specific control applications – regardless of their scope – and extended at any time to include personnel and assets, and even to integrate entire business operations.

Pre-built Templates: Solution pack with a wide range of templates ideal for general control applications.

Built-in Function Blocks: Designed to suit pharmaceutical applications and DCS requirements with specific function blocks, as well as support Custom Algorithm Blocks for building user-defined algorithms and data structures.

Application Development Toolkit: Develop custom applications that communicate with PlantCruise through the Network Application Programming Interface (API), Server API, Open Database Connectivity (ODBC) Data Exchange, Server Automation Object, etc.

FTE: Reliable, industrial-grade network providing multiple communication paths between nodes – thus eliminating all single points of failure –and utilizing commercial Ethernet technology for lower costs.

Direct Station: Powerful operator station functions as a client to the PlantCruise Engineering Server, and at the same time, allows direct access to the C300 controller for process data, alarms and messages.

Safe Operations: In collaboration with the Abnormal Situation Management (ASM[®]) Consortium, Honeywell has developed safe operator functions like Procedural Operations to reduce incidents related to improper execution of operating procedures. It has also created alarm handling and display layouts to improve overall operator response to abnormal conditions.

Experion PPC: Experion[®] PPC (Panel PC) is an industrial grade Touch Panel PC that extends Experion HMI for field operations and control at the machine and/or process level. This robust, easy to maintain hardware is built on open industry standards and provides the proven Experion User Interface with comprehensive data integration capabilities and consistent HMI experience that improves operator effectiveness.

Experion PPC can perform field level operations as a remote Station to PlantCruise and provide operational agility, improved operator workflow and standardization of HMI experience.



Experion PPC for Field Operations



Honeywell's robust Experion S8 C300 controller

C300 Controller: The Experion C300 controller operates Honeywell's deterministic Control Execution Environment (CEE) software, which executes control strategies on a consistent and predictable schedule.

ControlEdge Family of Controllers: PlantCruise is a DCS and SCADA solution which offers a single point solution covering a variety of controllers and unified HMI experience and operations.

Honeywell offers a wide range of ControlEdge family of controllers including

- ControlEdge PLC for equipment and skid level PLC control
- ControlEdge HC900 for hybrid control and SIL2 Safety control
- ControlEdge RTU2020 for remote asset monitoring

These controllers provide secure connectivity to all levels of process and business functions, optimized operations and maintenance efficiencies to meet your diverse automation needs. These controllers are designed to complement the S8 C300 platform by providing a fully integrated automation solution. When combined with PlantCruise the ControlEdge family of controllers help reduce integration and maintenance efforts, minimizes downtime, and reduces total cost of ownership.

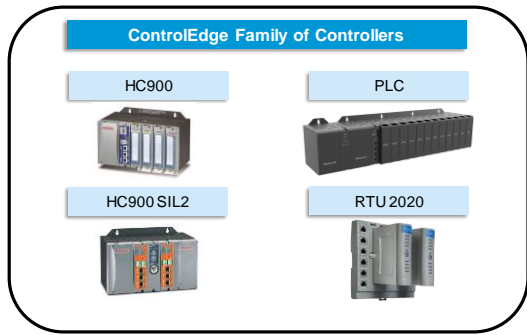

Honeywell's ControlEdge Family

Batch Automation

Honeywell has a rich legacy and commitment to batch automation. Besides offering industry-leading batch solutions for over 20 years, Honeywell was one of the founding members of the S88 Batch Standards Committee and continues to participate in committee activities. In addition, Honeywell is also a founding sponsor and frequent speaker at the World Batch Forum (WBF) both in the Americas and EMEA. Honeywell offers scalable batch solutions that can range from simply turning a pump on or off, to automating an equipment startup procedure, to fully implementing an S88 batch solution. Honeywell has pioneered the industry's most reliable, configurable batch automation solution resulting in gains of 2-5 percent production throughput compared to other solutions.

Our batch solution is an inherent function of the PlantCruise control environment, enjoying seamless interoperability with Experion control functions like alarming, history, mobile tools, real-time visualization of the batch sequences, and intuitive operator displays based on ASM Consortium principles. This delivers a unique, integrated environment to the operator, boosting productivity, efficiency and reliability.

Honeywell's S88 compliant solution for batch automation is scalable and can be fully redundant. Sequences are constructed via drag and-drop operations and include built-in functions for operator messages, abnormal condition handlers, mode propagation and more.

Templates are available to minimize engineering time.

Using S88 concepts and starting with simple sequence control, batch applications can be constructed using layering techniques to create simple or sophisticated batch automation within the controller. The controller-based batch layers provide unmatched reliability by eliminating several components that are capable of failing and causing production losses.

Also, through elimination of communication between the controller and server at every step transition, batch cycle times can be improved. As the level of sophistication increases, the batch environment can expand to include server-based batch functionality if needed. The user decides what level of automation makes the most sense. Reporting, management of formula sets, validation and other advanced capabilities are also available.

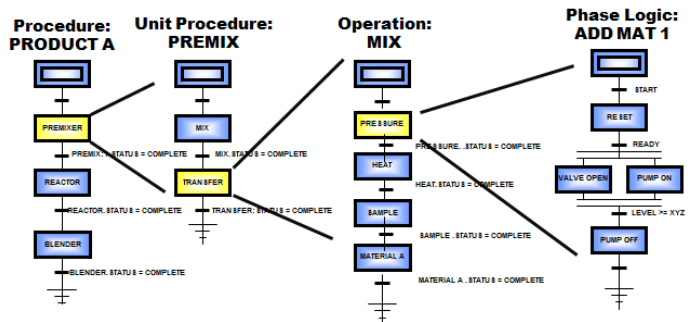

Sample Batch Procedures

Honeywell allows users to determine the approach that best meets their batch processing needs, whether it is standalone controller based procedures or higher level batch management on a server. Processes with limited or no unit coordination, fixed procedures and a small number of formulas and/or infrequently changing formulas are the most likely candidates for the controller-based approach. These processing operations typically need to repeat batches through standardized sets of equipment that offer higher availability, simplicity, and reliability. Where there is complex unit coordination, a large number of procedures and/or frequently changing procedures, and more complex recipe management, a server-based solution can be combined with the controller functions for a comprehensive solution.

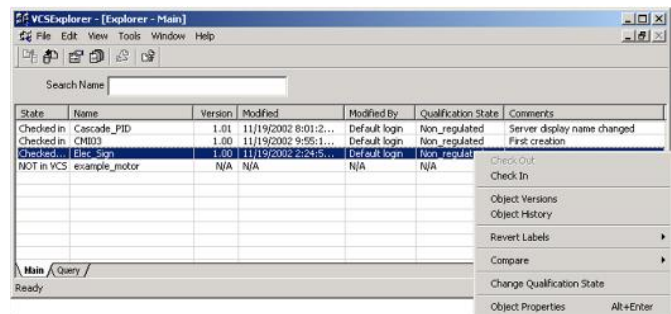

OVCS with Detailed Check-in and Check-out Features

The Qualification and Version Control System (QVCS) capabilities of PlantCruise establish well-enforced lifecycle and implementation procedures and reduce the number of Standard Operating Procedures (SOPs) while eliminating manual signatures and paper trails. They support U.S. Food and Drug Administration (FDA) Title 21 Code of Federal Regulations (21 CFR Part 11) compliance and provide the following key benefits:

- User-defined development cycle for easy process control management and compliance
- Comprehensive version history and audit trail for system protection and accountability
- User-defined electronic signature qualification

This solution also provides detailed check-in and checkout facilities to protect the change control process.

Features unique to QVCS, not contained in a manual system, include qualification lifecycle support, version control traceability, support of a version control system toolbar, and a full version history and audit trail. The history and audit trail allow the system to keep detailed records that meet FDA regulations and GAMP guidelines.

Honeywell's technical excellence and clause-by-clause analysis of 21 CFR Part 11, 210 and 211 have helped develop a system that reflects functionality and usability, while delivering a groundbreaking best-in-class product that will maintain regulatory compliance and reduce the cost of compliance.

Complementary Offerings

Process Optimization

Honeywell's Profit Loop is a single input/single output (SISO) model predictive control application specifically designed with the operating simplicity of a standard PID controller. This technology, which is tightly integrated into PlantCruise, is a Smith Predictor, gap controller and optimizer all in one that is used to control discrete analyzers, tank levels, long process delays and more. Profit Loop can reduce valve travel and wear, provide better control and reduce the possibility of controller windup. Because Profit Loop is tightly integrated with PlantCruise, specialty chemical users can incorporate Profit Loop into complex and custom control strategies, driving better control of their processes.

OPC Integration

OPC (OLE for Process Control) consists of a set of standards that define interoperability among different automation and control applications, field systems and devices, and business and office applications. OPC provides

data from a data source (server) and communicates the data to any client application in a standard way, thereby eliminating the requirement for an application to have specific knowledge about a particular data source, such as its internal structure and communications protocols. Experion integrates OPC with DCS technology to create the most flexible and powerful OPC suite available, with a broad range of Client, Server and redundancy OPC technologies.

History

The PlantCruise historian is a fully integrated, on-board historian. Users can collect standard history snapshots and averages, fast history snapshots down to one second or extended history snapshots. Configuration of history is done at the same time and using the same tool as database configuration. There are no separate databases to maintain or synchronize with PlantCruise. Historical data can be archived and made available for use by fast history, custom displays, reports, application programs, spreadsheets, ODBC compliant databases or other uses.

Equipment Procedures

Automating routine or infrequent equipment procedures integrates best practices for batch turnarounds, catalyst regeneration, filter change-out and system startup/shutdowns to improve operator performance, reduce cycle times and improve quality. This capability prevents downtime by capturing knowledge gained by operators over years of performing cyclic procedures – knowledge that could otherwise be lost as the workforce transitions. Steps for executing these procedures are available in the control system, ensuring that these tasks are done consistently, correctly and efficiently every time. Automating operator procedures can reduce the time to perform product changeovers or equipment procedures by as much as 40 percent.

Field Device Manager (FDM)

Honeywell Field Device Manager (FDM) simplifies maintenance tasks, saves time and provides the flexibility and scalability to perform complete device configuration and management tasks in the plant environment through smart plant instrumentation.

FDM is a centralized asset management system for remote configuration and maintenance of smart field devices based on HART, PROFIBUS and Fieldbus Foundation protocols. FDM is integral to supporting Experion-connected devices, yet it easily handles non-Experion networks. FDM supports a large number of devices through FDM clients connected to multiple, distributed FDM servers. With complete command and control of all instruments through the plant, FDM saves time by greatly reducing the number of field trips that would otherwise be required. By simplifying and reducing effort normally involved in plant debugging, FDM improves overall asset effectiveness.

Material Handling

Raw materials and energy can contribute between 50-80 percent of COGS³, which makes accurate material handling a business imperative. Honeywell has a host of solutions to help manufacturers control and reduce raw material usage. For instance, our VersaFlow flow meters are available in electromagnetic, ultrasonic, vortex and Coriolis technologies. We also offer built-in algorithms and integration with Mettler-Toledo weighing terminals, which are integrated with PlantCruise through specialized interface function blocks to tighten material transfer control, decrease batch cycle time and improve production quality.

PlantCruise enables automation of manual material additions to improve repeatability, minimize material losses and prevent additions of wrong materials or quantities. Instructions to

the operator are seamlessly presented during the automated procedure and confirmation is captured in the report.

Manufacturing Execution Systems (MES)

Honeywell's MES portfolio manages production information, including the status of production runs, detailed unit operations, inventory and movement quantities, quality parameters and regulatory compliance information. It improves collaboration between supply chain planning, production planning and plant operations by capturing production plans and schedules, communicating approved activities to operators and enabling efficient capture of actual production information.

Experion Mobility Solution

Honeywell offers the widest range of visualization, collaboration and browser-based solutions in the industry. The following offerings are available for secure remote access to Experion displays, Experion history, trends and alarms:

- Experion Alarm Pager for alarms and events per email or sms alerts
- Experion Mobile Station- A mobile workforce productivity solution that enables users to access critical process information, alarms, historical data, graphics and other key functions directly from the field, via a wireless connection.
- Experion eServer for read-only access to custom graphics and trends by casual users
- Experion RESS node for secure Station access from desktop, tablet and laptop devices - provides remote access to all Station functions and Engineering tools
- Experion Collaboration Station - Intuitive large touch screen-based dashboard that benefits any modern control room and remote support team



Experion Mobile Station

Wireless Solutions

Honeywell is a leader in industrial wireless technology. Our portfolio includes wireless solutions for low-cost process monitoring, critical process control, virtual control rooms, operator productivity tools and resource tracking. Honeywell's OneWireless™ network provides manufacturers with one optimized multifunctional network that supports many applications with comprehensive end-to-end security. Supporting a mobile workforce, Mobile Station technology, an extension of Honeywell's Experion PKS, enables engineering, operations, and maintenance personnel to safely capture and share process data locally at the source. OneWireless focuses on applications that improve operations including:

- Capturing valuable plant information in places where it was not previously possible, utilizing mobile and wireless technologies that automate field operator activities and bring the control room to the field.
- Providing real-time, accurate and reliable process and asset data faster and at lower costs than traditional wired sensors.

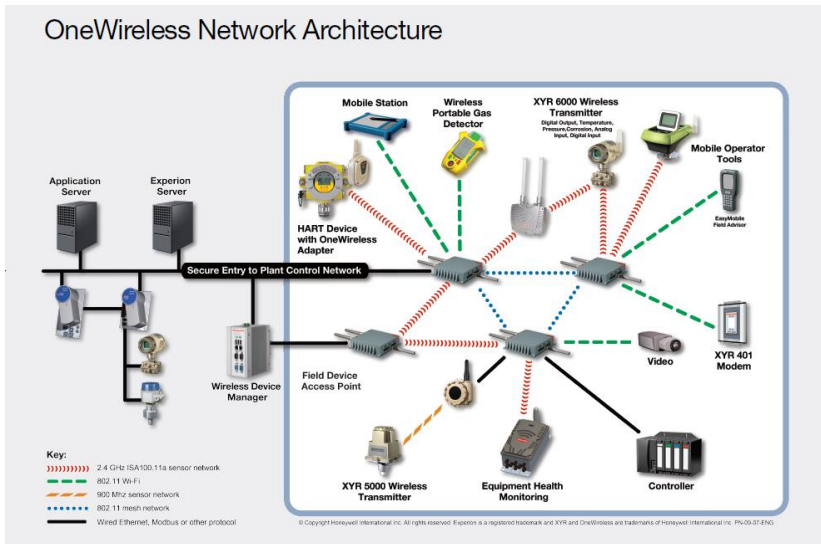

Energy Dashboard

Energy Dashboard gathers information from various instruments and systems so that energy consumption can be tracked against dynamic energy targets. Capturing and analyzing this data allows users to understand key energy indicators (KEI) and how they affect overall energy consumption. This enables specific goals for improving energy use and emissions reduction objectives to be established.

Also, the Energy Dashboard ensures that energy management flows from planning and business functions through to operations and provides the associated feedback. It captures raw energy data from the process and organizes it in a way that enables the user to quickly identify the big energy consumers and how they are doing against a set of appropriate targets.

Energy Management System

Honeywell offers Energy Management Systems, a customizable portfolio of hardware, software, and services to help improve energy efficiency and reduce greenhouse gas (GHG) emissions in energy intensive industrial processes. Users benefit from better energy management throughout their operations and increased profitability.

Energy Management Systems is a comprehensive offering that combines energy and process optimization and, where appropriate, incorporates the solution into online advanced control and optimization strategies. Additional components of the solution include:

- Heat and power recovery within and across process units using pinch analysis for improved integration
- Steam and power system optimization
- Calculation of dynamic energy and emission targets
- Feedstock selection
- Energy contract management
- The introduction of renewable energy sources such as biofuels
- Services to sustain and even improve results over time

Energy Management Systems can be implemented in stages starting with smaller-scale, quick return-on-investment projects and moving to more comprehensive, higher-value projects.

Summary

Honeywell's automation solution for chemicals manufacturing enables sites to boost performance and agility, enable easy process adjustments, increase batch repeatability, achieve reliability targets, improve quality and drive down costs – without the resources and investment of a large site. Batch producers with medium scale sites have limited resources and capital, and require a simple solution that provides the agility needed in the marketplace without sacrificing reliability and lifecycle costs. Honeywell's PlantCruise solution brings the value and reliability enjoyed by Honeywell customers around the world to medium scale operations, project implementation expertise and ongoing application support.

For More Information

To learn more about how Honeywell's PlantCruise by Experion can optimize your performance, visit www.plantcruise.com or contact your Honeywell account manager.

Honeywell Process Solutions

1250 West Sam Houston Parkway South
Houston, TX 77042

Honeywell House, Arlington Business Park
Bracknell, Berkshire, England RG12 1EB UK

Building #1, 555 Huanke Road, Zhangjiang
Hi-Tech Park, Pudong Shanghai, China

www.honeywellprocess.com

Experion® and Profit® are registered trademarks of Honeywell International Inc. All other trademarks are the property of their respective owners.
©2017 Honeywell International, Inc.

WP-17-20-ENG
Sept 2017
© 2017 Honeywell International Inc.

Honeywell